



**Chase  
Controls**

P.O. Box 1679  
Hot Springs, AR 71901  
PHONE: 501.262.3282  
FAX: 501.262.4847

## Product Data Sheet

---

### CC - 1000

#### Features:

---

- 32 Bit RISC Processor
- 2-RS232 Ports
- Optional 10/100Base T Port
- Modbus RTU Master/Slave Communications
- Expandable I/O
- Preprogrammed Applications Such As:
  - A. Pump Control
  - B. VFD Pump Control
  - C. Tank RTU
  - D. Valve Control
  - E. RTU Functionally for all applications
- Applications Configurable via User-Friendly Interface
- Integrated Hardware Watchdog Timer



The CC - 1000 is a dedicated application controller with all the power of a custom programmed PLC, in a user-friendly configurable platform. Chase Controls dedicated controllers, are designed and preprogrammed with multiple water and wastewater applications, ranging from simple pump / wet well control to complex water plant filter control, all in a single compact footprint.

This 32-bit controller offers the power and performance required for real-time communications, with short program scan times, as well as a wide range of digital and analog interface options. The controllers industry standard Modbus RTU communications, can be configured as a Modbus RTU Master or Slave, which simplifies integration with any SCADA software, HMI touch screen, and other intelligent instrumentation.

The CC - 1000 provides flexible communication with 2 serial RS232 ports and for applications using Ethernet LAN or WAN, an optional 10/100BaseT Ethernet port is available. For those challenging remote applications, the CC - 1000 supports connection over serial radio, Ethernet radio, cellular radio, and phone lines.

## Specifications

**Controller**

<b>Processor</b>	CPU 32 Bit microcontroller, integrated watchdog timer
<b>Memory</b>	8 MB SRAM, 8 MB Flash ROM
<b>Non Volatile RAM</b>	CMOS RAM w/ lithium battery retains contents for 2 years with

**I/O**

<b>Digital IN</b>	CC - 1000	8-16	90-120VAC, 47-63 Hz
	CC - 1000-D	8-16	12-24VDC, Sink or Source
<b>Digital OUT</b>	CC - 1000	6-14	6-240VAC / 6-27VDC, 2Amp
	CC - 1000-D	6-14	6-240VAC / 6-27VDC, 2Amp
<b>Analog IN</b>	CC - 1000 / -D	4-8	0-20ma, 4-20ma, 0-5V, 0-10V
<b>Analog OUT</b>	CC - 1000 / -D	4-8	0-20ma, 4-20ma, 0-10V

**Communications**

<b>Integrated Ports</b>	2—RS232 Serial, 6 Pin RJ-12
<b>Baud Rate</b>	Selectable 300-38,400 baud
<b>Serial Protocols</b>	Modbus RTU (Master / Slave)
<b>Optional</b>	10/100BaseT Ethernet, RJ-45
<b>Ethernet Protocols</b>	Modbus TCP/IP

**General**

<b>Terminals</b>	Removable Terminal Blocks, 16-22AWG, 15Amp Contacts
<b>Dimensions</b>	4.72 in wide X 3.74 in high X 2.56 in deep
<b>Temperature</b>	-4 Deg F to + 158 Deg F
<b>Humidity</b>	5% RH to 95% RH, non-condensing
<b>Vibration</b>	MIL STD 810C, Method 514.2
<b>Shock</b>	MIL STD 810C, Method 516.2
<b>Power</b>	CC - 1000 95-240VAC CC - 1000-D 12-24VDC

**Chase Controller CC-1000**

**Pump Control Simplex / Duplex Wetwell (Pump Down)  
w/ Discrete Pump Call**

<u>Inputs</u>	<u>Description</u>	<u>Outputs</u>	<u>Description</u>
X0	General Alarm	Y0	P1 Call
X1	P1 Auto	Y1	P2 Call
X2	P1 Aux	Y2	P1 Fail
X3	P2 Auto	Y3	P2 Fail
X4	P2 Aux	Y4	Alarm Light
X5	Lead Float	Y5	Alarm Horn
X6	Lag Float		
X7	Off Float		

<u>Expansion</u>	<u>8 AC Input</u>
X100	P1 High Temp
X101	P2 High Temp
X102	P1 Seal Fail (Pump Down)
X103	P2 Seal Fail (Pump Down)
X104	High Level
X105	P1 LEAD / No Alternation
X106	P2 LEAD / No Alternation
X107	Horn Silence / Fail Reset

**Pump Control Simplex / Duplex Tank (Pump Up)  
w/ Discrete Pump Call**

<u>Inputs</u>	<u>Description</u>	<u>Outputs</u>	<u>Description</u>
X0	General Alarm	Y0	P1 Call
X1	P1 Auto	Y1	P2 Call
X2	P1 Aux	Y2	P1 Fail
X3	P2 Auto	Y3	P2 Fail
X4	P2 Aux	Y4	Alarm Light
X5	Lead Pump Call	Y5	Alarm Horn
X6	Lag Pump Call		
X7	Configurable		

<u>Expansion</u>	<u>8 AC Input</u>
X100	P1 High Temp
X101	P2 High Temp
X102	Low Suction (Pump Up)
X103	High Discharge (Pump Up)
X104	High Level
X105	P1 LEAD / No Alternation
X106	P2 LEAD / No Alternation
X107	Horn Silence / Fail Reset

**Configurable Discrete Input Choices:**

- 1 Remote Data Read Only
- 2 P1 Seal Fail
- 3 P2 Seal Fail
- 4 Common Seal Fail
- 5 High Level Float
- 6 P1 High Temp
- 7 P2 High Temp
- 8 P1 LEAD / No Alternation
- 9 P2 LEAD / No Alternation
- 10 Low Suction
- 11 High Discharge
- 12 Horn Silence / Alarm Reset

**Pump Control Simplex / Duplex Wetwell (Pump Down)  
w/Remote Modbus Level & Setpoints**

<u>Inputs</u>	<u>Description</u>	<u>Outputs</u>	<u>Description</u>
X0	Power Interrupt	Y0	P1 Call
X1	P1 Auto	Y1	P2 Call
X2	P1 Aux	Y2	P1 Fail
X3	P2 Auto	Y3	P2 Fail
X4	P2 Aux	Y4	Alarm Light
X5	Configurable	Y5	Alarm Horn
X6	Configurable		
X7	Configurable		

<u>Expansion</u>	<u>8 AC Input</u>
X100	P1 High Temp
X101	P2 High Temp
X102	P1 Seal Fail (Pump Down)
X103	P2 Seal Fail (Pump Down)
X104	High Level
X105	P1 LEAD / No Alternation
X106	P2 LEAD / No Alternation
X107	Horn Silence / Fail Reset

**Pump Control Simplex / Duplex Tank (Pump Up)  
w/Remote Modbus Level & Setpoints**

<u>Inputs</u>	<u>Description</u>	<u>Outputs</u>	<u>Description</u>
X0	Power Interrupt	Y0	P1 Call
X1	P1 Auto	Y1	P2 Call
X2	P1 Aux	Y2	P1 Fail
X3	P2 Auto	Y3	P2 Fail
X4	P2 Aux	Y4	Alarm Light
X5	Configurable	Y5	Alarm Horn
X6	Configurable		
X7	Configurable		

<u>Expansion</u>	<u>8 AC Input</u>
X100	P1 High Temp
X101	P2 High Temp
X102	Low Suction (Pump Up)
X103	High Discharge (Pump Up)
X104	High Level
X105	P1 LEAD / No Alternation
X106	P2 LEAD / No Alternation
X107	Horn Silence / Fail Reset

**Pump Control Simplex / Duplex Wetwell (Pump Down)**

**w/Pressure Transducer & Setpoints**

<u>Inputs</u>	<u>Description</u>	<u>Outputs</u>	<u>Description</u>
X0	Power Interrupt	Y0	P1 Call
X1	P1 Auto	Y1	P2 Call
X2	P1 Aux	Y2	P1 Fail
X3	P2 Auto	Y3	P2 Fail
X4	P2 Aux	Y4	Alarm Light
X5	Configurable	Y5	Alarm Horn
X6	Configurable		
X7	Configurable		

**Expansion**      **4 Analog In**

AI 1	Tank / Wetwell Xducer
AI 2	
AI 3	
AI 4	

**Pump Control Simplex / Duplex Tank (Pump Up)**

**w/Pressure Transducer & Setpoints**

<u>Inputs</u>	<u>Description</u>	<u>Outputs</u>	<u>Description</u>
X0	Power Interrupt	Y0	P1 Call
X1	P1 Auto	Y1	P2 Call
X2	P1 Aux	Y2	P1 Fail
X3	P2 Auto	Y3	P2 Fail
X4	P2 Aux	Y4	Alarm Light
X5	Configurable	Y5	Alarm Horn
X6	Configurable		
X7	Configurable		

**Expansion**      **4 Analog In**

AI 1	Tank / Wetwell Xducer
AI 2	Suction PSI Xducer
AI 3	Discharge PSI Xducer
AI 4	

**Tank RTU Control**

<u>Inputs</u>	<u>Description</u>	<u>Outputs</u>	<u>Description</u>
X0	Power Interrupt	Y0	
X1		Y1	
X2		Y2	
X3		Y3	
X4		Y4	Tank Low Alarm
X5		Y5	Tank High Alarm
X6			
X7			

**Expansion**      **4 Analog In**

AI 1	Tank Xducer
AI 2	
AI 3	
AI 4	

## CC - 2000

### Features:

---

- 32 Bit RISC Processor
- 1-RS232 Port
- 1-RS232/RS485 Port
- Optional 10/100Base T Port
- Modbus RTU Master/Slave Communications
- Expandable I/O
- Preprogrammed Applications Such As:
  - A. Pump Control
  - B. VFD Pump Control
  - C. Tank RTU
  - D. Valve Control
  - E. Water Plant Filter Control
  - F. RTU Functionality for all applications
- Applications Configurable via User-Friendly Interface
- Integrated Hardware Watchdog Timer



---

The CC - 2000 is a dedicated application controller with all the power of a custom programmed PLC, in a user-friendly configurable platform. Chase Controls dedicated controllers, are designed and preprogrammed with multiple water and wastewater applications, ranging from simple pump / wet well control to complex water plant filter control, all in a single compact footprint.

This 32-bit controller offers the power and performance required for real-time communications, with short program scan times, as well as a wide range of digital and analog interface options. The controllers industry standard Modbus RTU communications, can be configured as a Modbus RTU Master or Slave, which simplifies integration with any SCADA software, HMI touch screen, and other intelligent instrumentation.

The CC - 2000 provides flexible communication with 2 serial RS232/RS485 ports and for applications using an Ethernet LAN or WAN, a optional 10/100BaseT Ethernet port is available. For those challenging remote applications, the CC - 2000 supports connection over serial radio, Ethernet radio, cellular radio, and phone lines.

## Specifications

**Controller**

<b>Processor</b>	CPU 32 Bit microcontroller, integrated watchdog timer
<b>Memory</b>	8 MB SRAM, 16 MB Flash ROM
<b>Non Volatile RAM</b>	CMOS RAM w/ lithium battery retains contents for 2 years with no power

**I/O**

<b>Digital IN</b>	CC - 2000	20-52	90-120VAC, 47-63 Hz
	CC - 2000-D	20-52	12-24VDC, Sink or Source
<b>Digital OUT</b>	CC - 2000	16-48	6-240VAC / 6-27VDC, 2Amp
	CC - 2000-D	16-48	6-240VAC / 6-27VDC, 2Amp
<b>Analog IN</b>	CC - 2000 / -D	4-32	0-20ma, 4-20ma, 0-5V, 0-10V
<b>Analog OUT</b>	CC - 2000 / -D	4-32	0-20ma, 4-20ma, 0-10V

**Communications**

<b>Integrated Ports</b>	1—RS232 Serial, 6 Pin RJ-12, 1—RS232/RS485 15 Pin DB15HD
<b>Baud Rate</b>	Selectable 300-38,400 baud
<b>Serial Protocols</b>	Modbus RTU (Master / Slave)
<b>Optional</b>	10/100BaseT Ethernet, RJ-45
<b>Ethernet Protocols</b>	Modbus TCP/IP

**General**

<b>Terminals</b>	Removable Terminal Blocks, 16-22AWG, 15Amp Contacts
<b>Dimensions</b>	9.09 in wide X 5.0 in high X 2.56 in deep
<b>Temperature</b>	-4 Deg F to + 158 Deg F
<b>Humidity</b>	5% RH to 95% RH, non-condensing
<b>Vibration</b>	MIL STD 810C, Method 514.2
<b>Shock</b>	MIL STD 810C, Method 516.2
<b>Power</b>	CC - 2000 95-240VAC CC - 2000-D 12-24VDC

Chase Controller CC-2000

**Pump Control (1-6 Pumps) Discrete Or Analog Level Control**

**Wetwell (Pump Down) or Tank (Pump Up)**

<u>Cntrl Address (Inp)</u>	<u>Inputs</u>	<u>Description</u>	<u>Outputs</u>	<u>Description</u>	<u>Configurable Discrete Input Choices:</u>	
					<u>Cntrl Address (Inp)</u>	
X0	X0	Power Fail (On=Armed, Off=OK)	Y0	P1 Call	1	Remote Data Read Only
B3717.0	X1	P1 Auto	Y1	P2 Call	2	B3722.8 P1 Seal Fail (Pump Down) / <b>Low Suction (Pump Up)</b>
B3720.8	X2	P1 Aux	Y2	P3 Call	3	B3722.9 P2 Seal Fail (Pump Down) / High <b>Discharge (Pump Up)</b>
B3717.1	X3	P2 Auto	Y3	P4 Call	4	B3722.10 P3 Seal Fail
B3720.9	X4	P2 Aux	Y4	P5 Call	5	Common Seal Fail
C10	X5	P3 Auto	Y5	P6 Call	6	B3722.0 P1 High Temp
C13	X6	P3 Aux	Y6		7	B3722.1 P2 High Temp
C11 / C14	X7	Horn Silence / Fail Reset	Y7		8	B3722.2 P3 High Temp
	X10	Configurable	Y10	P1 Fail	9	C34 P1 LEAD / No Alternation
	X11	Configurable	Y11	P2 Fail	10	C35 P2 LEAD / No Alternation
	X12	Configurable	Y12	P3 Fail	11	C36 P3 LEAD / No Alternation
	X13	Configurable	Y13	P4 Fail	12	P4 Auto
	X14	Configurable	Y14	P5 Fail	13	P5 Auto
	X15	Configurable	Y15	P6 Fail	14	P6 Auto
	X16	Configurable	Y16	<b>Alarm Light</b>	15	P4 Aux
	X17	Configurable	Y17	<b>Alarm Horn</b>	16	P5 Aux
	X20	Lead Float			17	P6 Aux
	X21	Lag Float				
	X22	Off Float				
C33	X23	High Level				
	<b>Expansion</b>	<b>4 Analog In</b>				
	AI 1	Tank / Wetwell Xducer				
	AI 2	Suction PSI Xducer (Pump Up Only)				
	AI 3	Discharge PSI Xducer (Pump Up Only)				
	AI 4	Flow				

**Tank RTU Control**

<u>Inputs</u>	<u>Description</u>	<u>Outputs</u>
X0	Power Interupt	Y0
X1		Y1
X2		Y2
X3		Y3
X4		Y4
X5		Y5
X6		
X7		
X10		
X11		
X12		
X13		
X14		
X15		
X16		
X17		
X20		
X21		
X22		
X23		
<u>Expansion</u>	<u>4 Analog In</u>	
AI 1	Tank Level	
AI 2		
AI 3		
AI 4		

## CC - 3000 Controller

### Features:

---

- Intel 64 Bit 2-Core 1.6GHz Processor
- 2-Rs232/485 Port (Standard), Expandable to 4
- Standard 10/100/1000 Mb/s Ethernet Port
- Modbus RTU Master/Slave Communications
- Chase Controls DLP Protocol Communications
- Windows OPC Data Communications
- Expands IO by connecting RIO Modules
- Field Programmable Logic via Industry Standard IEC -61131-3 ISaGRAF V5.2
- Applications Configurable via User-Friendly GUI
- Integrated Hardware Watchdog Timer
- Windows Embedded Industrial OS



---

PLC's provide a great solution for many applications, but when your application goes beyond straight- forward ladder logic controlling simple I/O, Chase Controls CC-3000 Industrial controller is the smarter way to go. The CC-3000 is a controller with high performance Intel Dual Core CPU. Built-in Windows Embedded operating system makes the CC-3000 a ready application platform to shorten development time. Connecting with Chase Controls Remote IO I/O modules, the CC-3000 can become a complete control system.

The CC-3000 utilizes ISaGRAF the industry standard IEC6113-3 automation software. ISaGRAF provides a user-friendly, flexible environment for developing, debugging and downloading CC-3000 controller logic code; and provides local and remote access to your process by utilizing Intranet and Internet technologies. The IEC 61131-3 software package includes the five main languages: Sequential Function Chart (SFC), Instruction List (IL), Ladder Diagram (LD), Function Block Diagram (FBD), and Structured Text (ST). In addition to these languages a sixth, called Flow Chart (FC) is included. This sixth language is graphics-based and used to describe sequential operations in an application.

## Specifications

**Controller**

**Processor** CPU Intel 64 Bit dual-core microcontroller, integrated watchdog timer

**Memory** 2 GB SRAM Standard, 16 GB SRAM Maximum

**Non Volatile RAM** 32 GB Sold State SATA Storage Drive

**I/O**

**Digital IN** Limited By Protocol Only

**Digital OUT** Limited By Protocol Only

**Analog IN** Limited By Protocol Only

**Analog OUT** Limited By Protocol Only

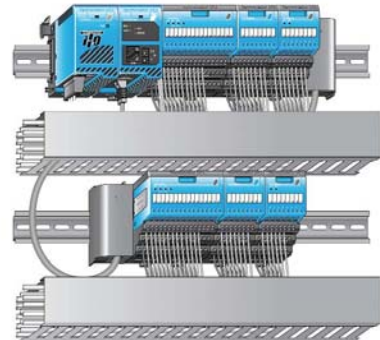
**Communications**

**Integrated Ports** 2—RS232/485 Serial, 5-USB, Analog VGA, 2 SATA, 10/100/1000 Mbs TCP/IP

**Baud Rate** Selectable 300-230,000 baud

**Serial Protocols** Modbus RTU (Master / Slave), Chase DSL, DNP, AB DF-1, others on request

**Ethernet Protocols** Modbus TCP/IP, AB TCP/ IP, DNP, Chase DSL, others on request

**General**

**Terminals** Removable Terminal Blocks, 16-22AWG, 15Amp Contacts

**Dimensions** 7.5 in wide X 8.25 in high X 2.50 in deep

**Temperature** 10 Deg F to + 158 Deg F

**Humidity** 5% RH to 95% RH, non-condensing

**Vibration** MIL STD 810C, Method 514.2

**Shock** MIL STD 810C, Method 516.2

**Power** 120 VAC / 18 VDC

## CC - D4M

### Features:

---

- Touch Screen Display
- 128X64 Dot display with up to 10 lines by 32 characters of text and graphics
- 5 Function Keys
- 768 KB Memory
- Panel Powered by CC - 1000 / CC - 2000 Serial Port
- 32 deg F to 122 deg F Operating Temperature
- 4.5" W X 3.25" H X 1.15" D
- NEMA 4/4X, IP-65 Compliant
- UL, cUL & CE Agency Approvals



---

The CC - D4M Graphic Display has a 3.1 inch STN LCD monochrome display. It features a 120X 64 dot display, and five function keys, each with a reed LED indicator. The panel can display up to 10 lines by 32 characters of text, mixed with graphics. It is rated NEMA 4/4X, IP-65 (when mounted correctly). The CC-D4M panel receives power from the serial communications port of Chase Controls, controllers.

## CC - D6C

### Features:

---

- Touch Screen Color Display
- 320 X 240 pixel display with up to 40 lines by 80 characters of text and graphics
- 5 Function Keys
- 32K Colors
- 24 VDC Power
- 15 Pin RS232 / RS485 Serial Port
- USB Type B Port
- Standard Communication Protocols:
  - Modbus RTU
  - Allen Bradley DF1 Full Duplex, Allen Bradley DF1 Half Duplex, Allen Bradley PLC5 DF1, AB DH485
  - Omron Host Link (C200 Adapter, C500)
  - Omron FINS serial (CJ1, CS1)
  - GE SNPX (90/30, 90/70, Micro 90, VersaMax Micro)
  - Mitsubishi Melsec FX
- 3,276 KB Memory
- 32 deg F to 122 deg F Operating Temperature
- 6.85"W X 5.3"H X 1.4"D
- NEMA 4/4X, IP-65 Compliant
- UL, cUL & CE Agency Approvals



### Description:

---

The CC-D6C Graphic touch panel has a 6-inch TFT LCD 320 x 240 dot display and a palette of 32K colors for customizing objects, screen backgrounds and displaying bitmap graphics. It features five user-defined function keys, each key with a user-defined red LED indicator. The panel can display up to 40 lines by 80 characters of static text and up to 40 lines by 40 characters of dynamic text with embedded variables and phrases mixed with graphics in landscape orientation. Portrait orientation can display 53 lines by 60 characters of static text and 40 lines by 40 characters of dynamic text. It is rated UL for use on a flat surface of Type 1, 4X enclosure. The CC-D6C Graphic TFT panels are powered from a 12-24 VDC power supply.

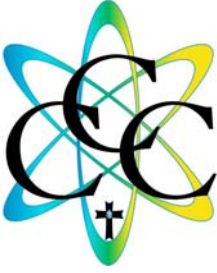

P.O. Box 1679  
Hot Springs, AR 71901  
PHONE: 501.262.3282  
FAX: 501.262.4847

## Water & Wastewater Level/Pressure Transducer

*CC 03271988-03042005 Series*

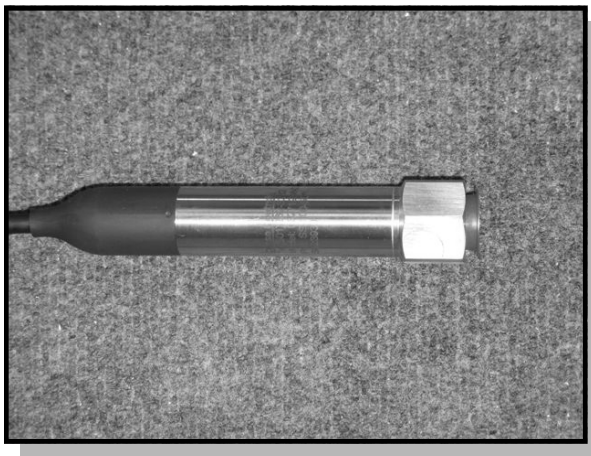

- Optional 0.1% & 0.25% accuracy
- Ranges 10"-50"WC, 5-150 PSI
- All welded 316L SS
- Optional Titanium Construction
- Molded polyurethane cable
- 4-20 mA, 2-wire
- FM(C) Class I, II, III, Div. 1, Groups A-G

**The CC 03271988-03042005 Series** submersible level/pressure transducers are specifically designed for use in water, wastewater, and industrial applications. The ceramic sensing element provides a rugged flush open face design which avoids clogging or sludge build up from materials often encountered in wastewater. The stainless steel construction will satisfy most applications. Where chemical environments dictate, an option of Titanium is available. The standard polyurethane vented cable is molded to the transducer providing the highest integrity waterproof assembly well proven in thousands of installations worldwide. The cable contains a Kevlar Strain Relief to preclude cable elongation. Teflon FEP cable is available as an alternate for harsh environments. The interior of the transducer is completely potted with polyurethane. Each transducer is furnished with a 1/2 inch MNPT connection and an adapter for a 1/4 inch MNPT connection.

## STANDARD SPECIFICATIONS

- **Sensor**  
Rugged flush face design, ceramic sensing element
- **Full Scale Ranges (Zero Based)**  
0-10, 20, 30, 50"WC  
0-5, 10, 15, 30, 50, 60, 75, 100, 150 psi  
Other ranges and pressure units can be specified

- **Accuracy**  
±0.1% FS (BSL) or ±0.25% FS (BSL)  
Combined non-linearity, hysteresis & repeatability

- **Overpressure**  
For full scale ranges up to 20 psi - 10X  
Above 20 to 150 psi-4X

- **Operating Temperature Range**  
-10° to +175° F (-20° to +80° C)

- **Compensated Temperature Range**  
30° to 85° F (-2° to +30° C)

- **Temperature Effects (Compensated)**  
High accuracy (±0.1)  
±0.3% Temperature error band for ranges 5 psi and above  
±1.0% Temperature error band for ranges below 5 psi

Standard accuracy (±0.25%)  
±1.5% Temperature error band for ranges 5 psi and above  
±2.0% Temperature error band for ranges below 5 psi

- **Electrical**  
2-wire, 4-20 mA, 10-35 Vdc power

- **Intrinsically Safe Approval**  
Available with FM Intrinsically Safe Certification for use in Class I, II, and III, Division 1, Groups A,B,C,D,E,F,&G hazardous locations.  
*Note: FMC approval is included for Canadian requirements.*

- **Cable**  
Molded Polyurethane vented cable with Kevlar Strain Relief  
Molded Teflon FEP cable is optional

- **Housing**  
316L Stainless Steel or Titanium  
*Note: 5-year corrosion warranty included for Titanium housing.*

- **Weight**  
7.6 oz. (excluding cable)

CC adopts a continuous development program which sometimes necessitates specification changes without notice.



## ORDERING INFORMATION

### CHASE CONTROLS Series Level/Pressure Transmitter

When ordering please specify the following:

#### MODEL - Construction

Model	
CC	
Housing Material	
SS	316 Stainless Steel
TT	Titanium - 5 year corrosion warranty
PSI/WC Range	
	0-5, 0-15 ect.
Cable length	
	Feet
Cable Type	
P	Polyurethane
F	Teflon FEP

(CC) (SS) (0100PSI) (50') (P)

## OPTIONS

1/2" FNPT Conduit Style CableConnection with 1/4" MNPT Adapter included

CC offers a range of accessories and variants for depth and

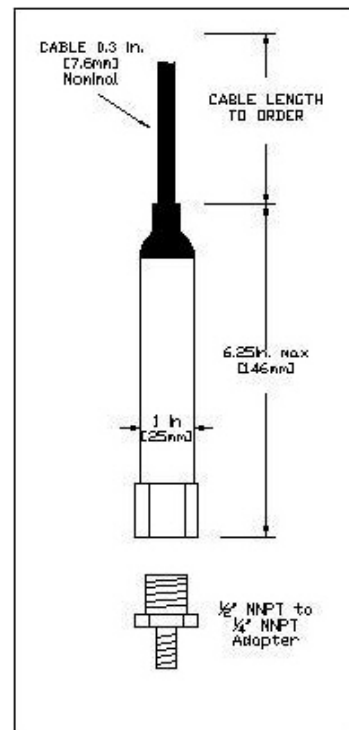

## Chase Controls Industrial Data Logging / Control System



### Features:

---

- 12-24VDC or 120-240 VAC
- Battery Backup
- 8 –120VAC Universal Digital Inputs to record / Log Discrete Inputs
- 6 – 120VAC 5A Relay Status/Alarm Outputs
- 4 Universal Analog Sensor Inputs
- 2 Universal Analog Control Outputs Analog Measurement Range: 0-30VDC, or 0-20/4-20ma, Thermocouple, RTD
- USB & External SATA Slots Available for Easy Data Transfer
- RS232, Ethernet 10/100, and USB Communication Ports
- Phone, Cell Phone, or Radio Modem Support Available
- Easy to Use Windows Based Configuration Software
- Measured Values can be logged as Raw or Scaled Engineered Units
- Stand-Alone, Real Time Network or Remote RTU Data Acquisition
- Remote Monitoring, Logging, and Control
- 16 X 18 X 10 NEMA 4X Fiber Glass Enclosure
- 15” Touch Display